



**SUPPLEMENTAL BID BULLETIN NO. 2022-06**

May 16, 2022

This Supplemental Bid Bulletin is issued to modify/amend items in the Bidding Documents, and shall be an integral part of the Bidding Document for the ***“Procurement of Goods and Services for the Fabrication and Delivery of Fiberglass Reinforced Plastic Motorized Fishing Boat”*** to wit:

**1. Section VII. Technical Specifications shall be corrected as follows:**

Item	Specification	Statement of Compliance
1	Labor and Materials for the Fabrication and Delivery of 18 units Fiberglass Reinforced Plastic (FRP) Motorized Fishing Boat: <b>1. 1 unit 38-footer FRP Boat installed with:</b> <ul style="list-style-type: none"> <li>• 4D30 or 4DR5 engine with complete accessories</li> <li>• underwater fittings such as:               <ul style="list-style-type: none"> <li>○ 1 ¼” Stainless Steel Shafting with thread and ring nut</li> <li>○ 1 ½” brass pipe</li> <li>○ 24”SS propeller, 3 blade</li> <li>○ 1 ¼” x 1 ½” ball joint</li> <li>○ 1 ¼”SS rudder assembly</li> <li>○ SS bolt and nut</li> <li>○ 1 lot outrigger</li> </ul> </li> <li>• <b>Color: Red, Yellow and White (as indicated in the Lay-out)</b></li> </ul>	
	<b>2. 11 units 30-footer FRP Boat installed with:</b> <ul style="list-style-type: none"> <li>• Marine Gasoline Engine (AMTEC Certified)               <ul style="list-style-type: none"> <li>○ with SS exhaust pipe</li> <li>○ 15-16 HP Net Power</li> <li>○ High Torque</li> </ul> </li> <li>• Underwater fittings               <ul style="list-style-type: none"> <li>○ ¾” SS shafting with thread and ring nut</li> <li>○ ¾”brass pipe</li> <li>○ ¾” x 9” SS propeller</li> <li>○ ¾” x 1” crossjoint with lock bolts</li> <li>○ ¾” SS rudder assembly</li> <li>○ SS bolt and nut</li> </ul> </li> <li>• <b>Color: Light Blue (see lay-out)</b></li> </ul>	



Republic of the Philippines

**DEPARTMENT OF AGRICULTURE**

**BUREAU OF FISHERIES AND AQUATIC RESOURCES**

Regional Fisheries Office No. 1

Government Center, Sevilla, San Fernando City, La Union 2500

Telefax: (072) 242-15-59 Tel. No.: (072) 607-5115

Email: [bfarfo1\\_records@yahoo.com](mailto:bfarfo1_records@yahoo.com)

**Help Stop Illegal Fishing! Report to BantayDagat Hotlines:**

**SUN: 0925-512-4203 / GLOBE: 0977-457-4911 /SMART: 0919-996-1078**



Certificate Number: SCUK000233Q

	<p><b>3. 6 units 15-footer FRP Boat installed with:</b></p> <ul style="list-style-type: none"><li>• Marine Gasoline Engine (AMTEC Certified)<ul style="list-style-type: none"><li>○ with SS exhaust pipe</li><li>○ 5.9 – 9 HP Net Power</li></ul></li><li>• Underwater fittings<ul style="list-style-type: none"><li>○ 5/8" Stainless Steel shafting with thread and ring nut</li><li>○ 3/4" brass pipe</li><li>○ 5/8" x 7" SS propeller</li><li>○ 5/8" x 1" cross joint with 2 lock bolts</li><li>○ 5/8" SS rudder assembly</li><li>○ SS bolt and nut</li></ul></li><li>• <b>Color: Red, Yellow and White (as indicated in the Lay-out)</b></li></ul>	
2	Materials (such as resin, fiberglass mats, etc) to be used should conform with BFAR Standards	
3	Contractor shall be responsible solely for manpower and bear all costs of labor and other expenses during the fabrication and delivery of units	
4	Costs Inclusive of all taxes and other fees	

Considering these changes, all prospective bidders shall follow these changes in preparing Technical and Financial proposals.

For the guidance and information of all concerned.

  
**GIRLY G. DELA PENA**  
BAC Chairperson

## Annex 1: 38-footer Motorized Fishing Boat



# 38-footer Tuna Handliner

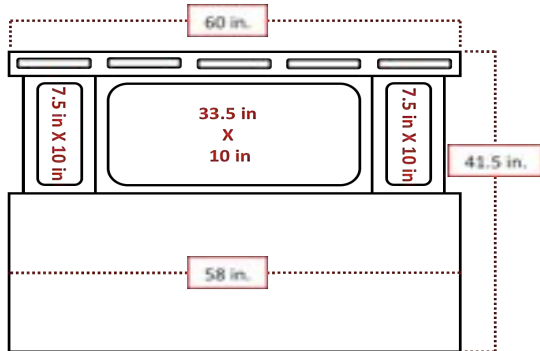
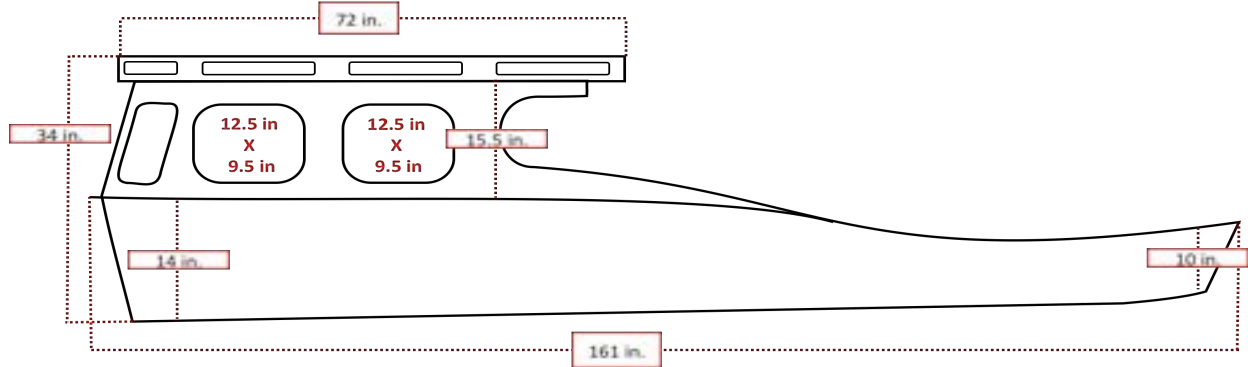
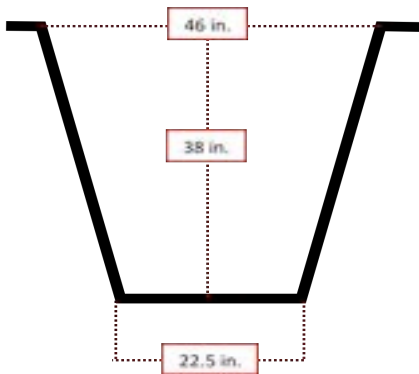
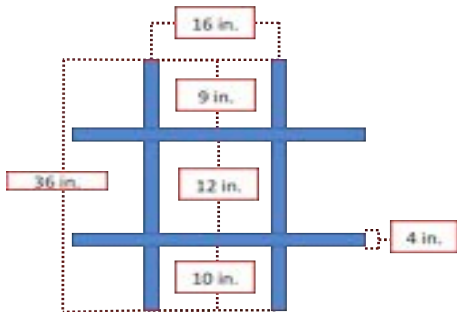

# 38-footer Tuna Handliner

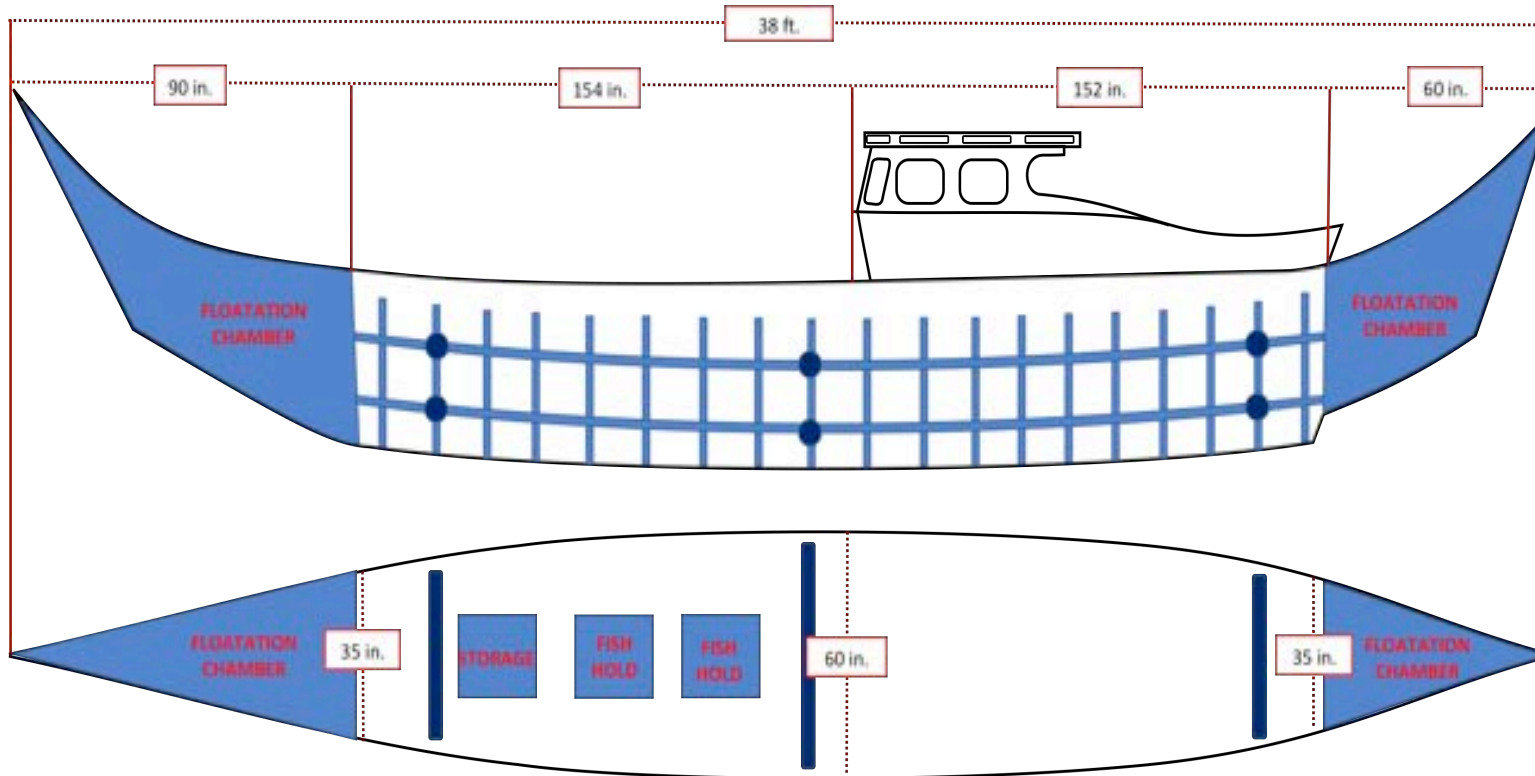

# 38-footer Tuna Handliner

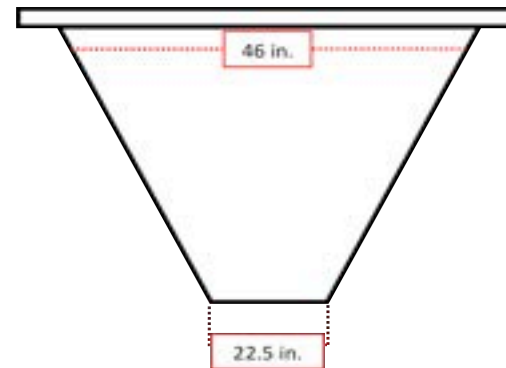
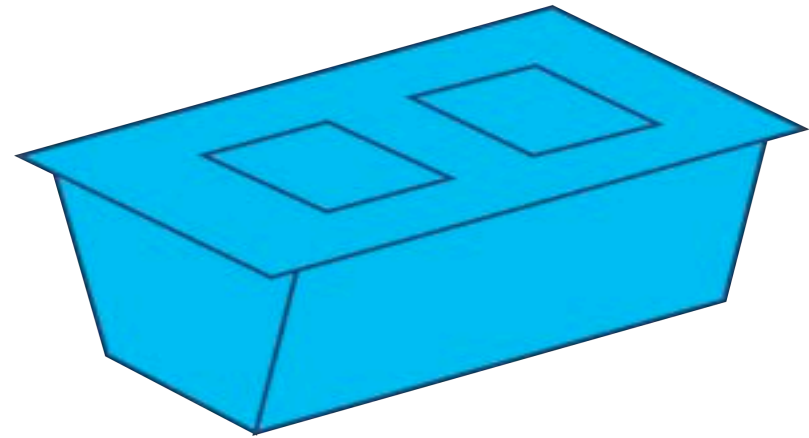
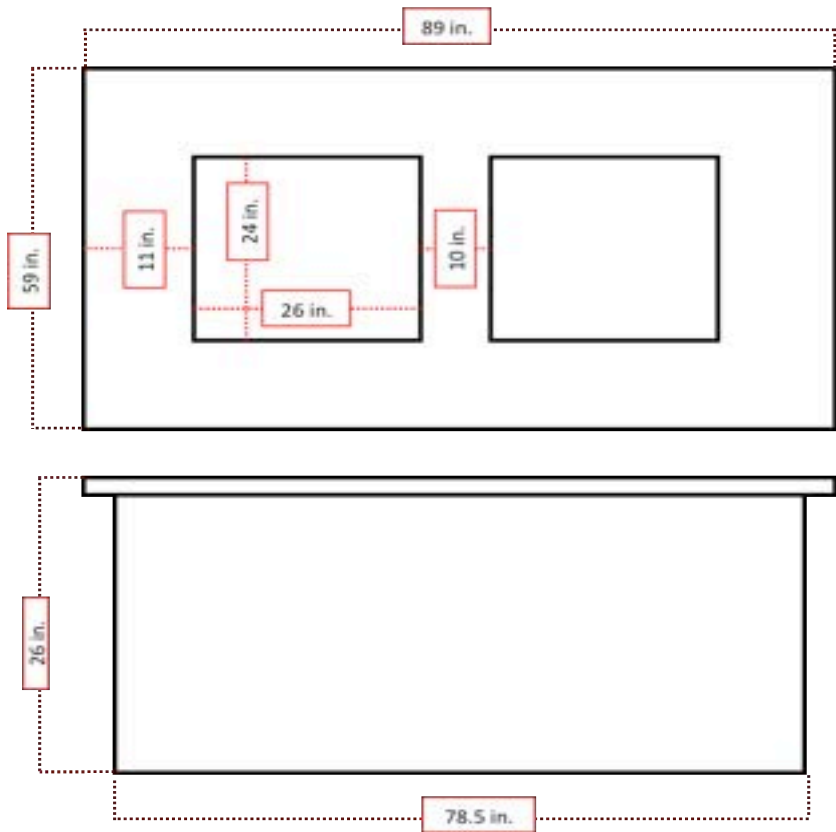

## 38-footer Tuna Handliner

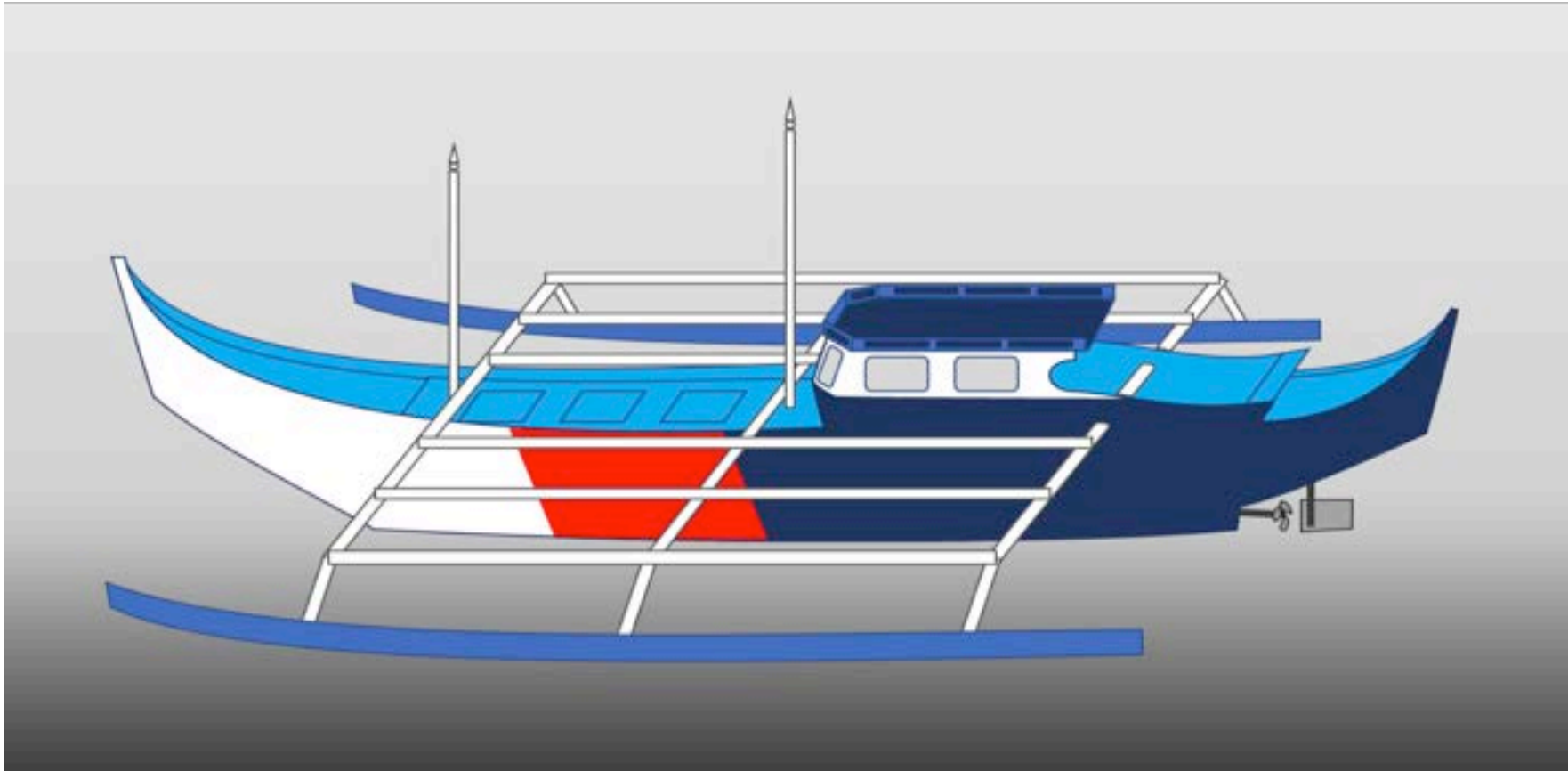

**Annex 2: 30-footer Motorized Fishing Boat**

**30-footer Fishing Boat**

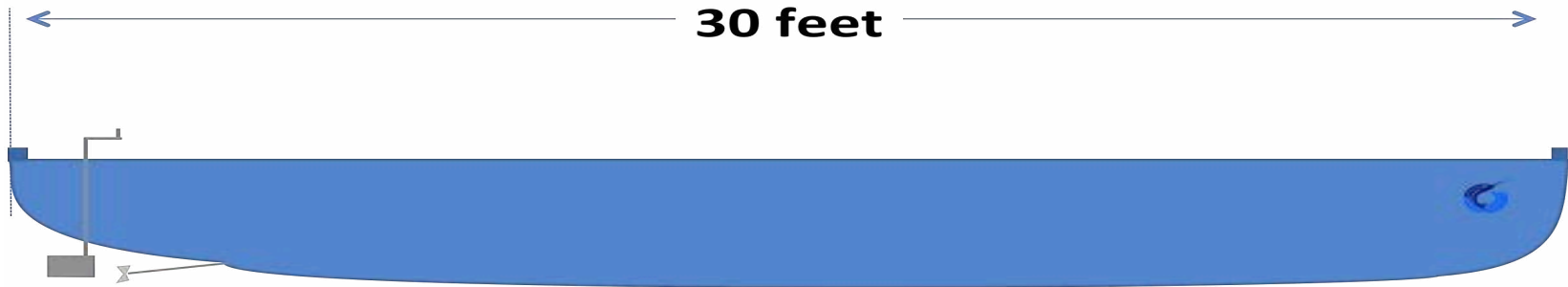

**Stern**



**Bow**

**Marking**

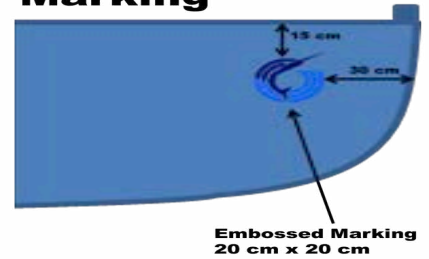



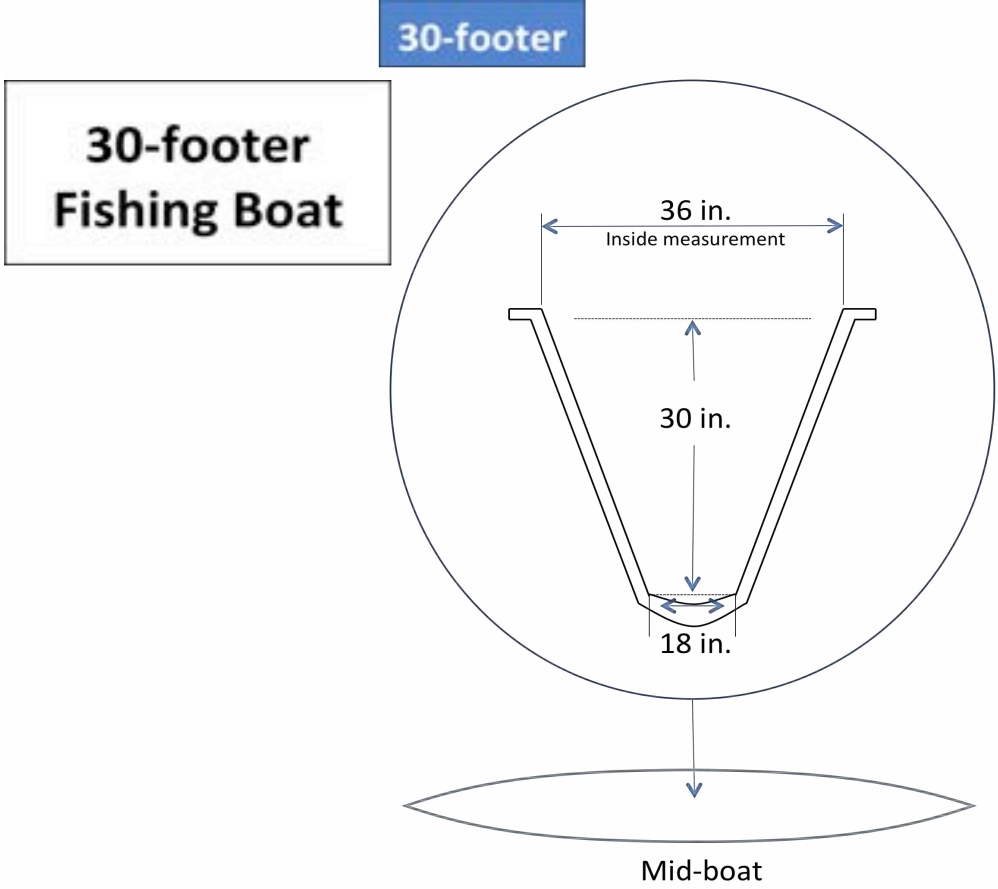

**Layer Specifications:**

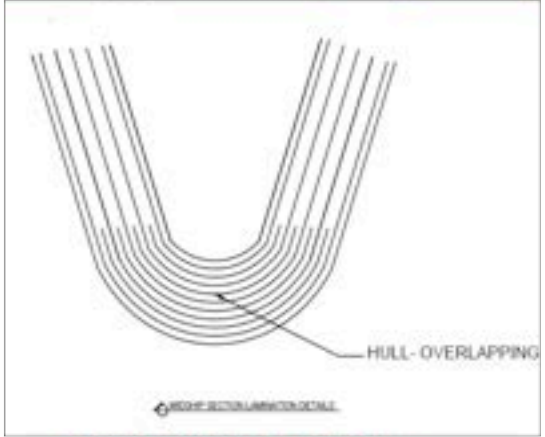
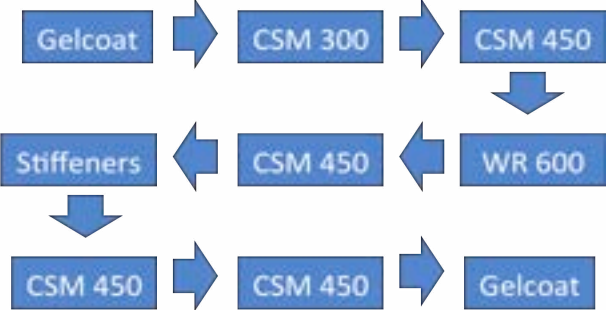

Please take note of the hull.

**30-footer  
Fishing Boat**

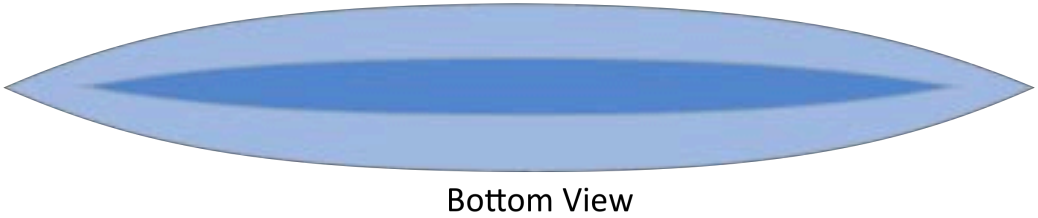
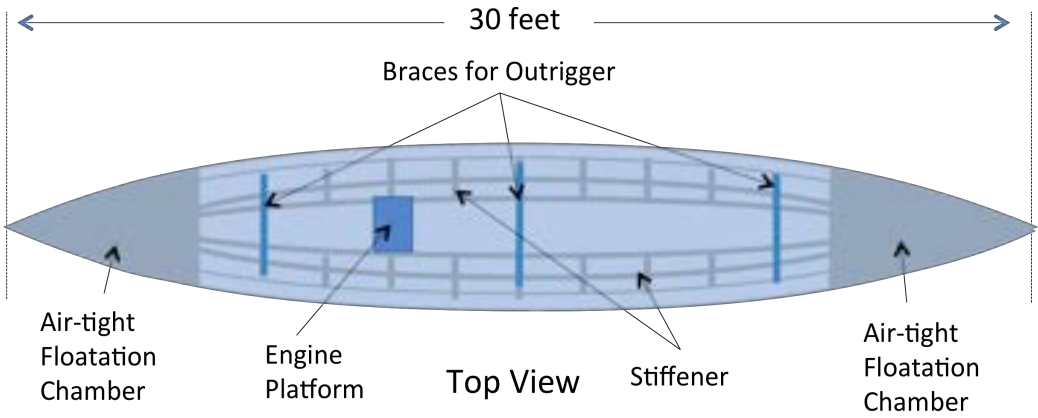

**Annex 3: 15-footer Motorized Fishing Boat**

**15-footer Pakura**

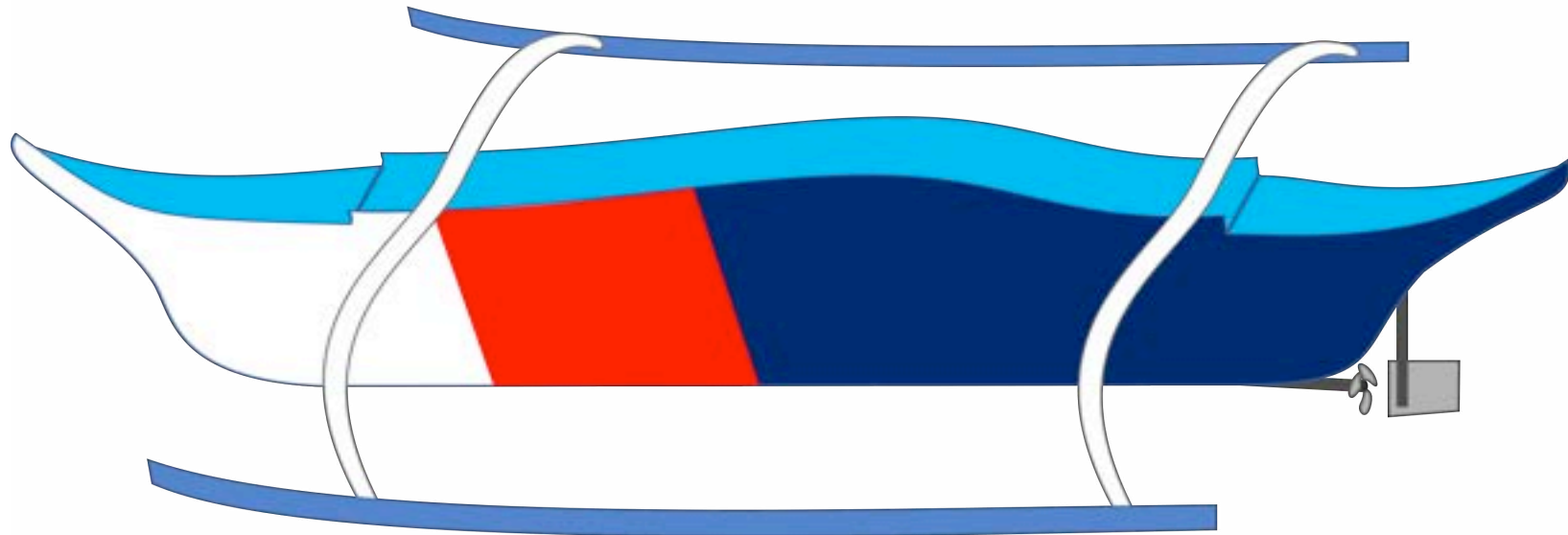

# 15-footer Pakura

